

# UT SENSOR

EXRAY™ utilizes two types of ultrasonic probes supplied by Cygnus Instruments: twin crystal (T5B) and single crystal (S2C).\*

Twin crystal probes are suited for measuring heavily corroded metals. Single crystal probes are ideal for reading through and ignoring coatings, operating in Multiple-Echo mode. They function in Echo-Echo mode, allowing them to read through and ignore up to 1 mm (0.040 inch) of surface coating, and in Single-Echo mode when there are no surface coatings. The frequency of the probes range from 2 MHz to 5 MHz and the overall weight of the UT Sensor is 1001 g (35.31 oz).

The UT Sensor is fully integrated with NAVIA™ without the need of an external system.



## SYSTEM SPECIFICATIONS

Probe T5B for M1-OEM

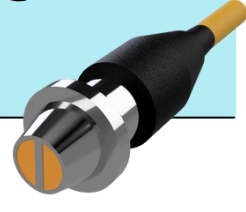
Frequency	5 MHz	
Tip Size	12.7 mm (0.5 in)	
Maximum Depth Rating	50 m (165 ft)	
Range in Steel (Single - Echo)	1.5 - 200 mm (0.059 - 7.90 in)	
Range in Steel (Echo Echo)	4 - 50 mm (0.16 - 2in)	
Temperature Range	-10°C to +70°C (14°F to 158°F)	

\*WE ARE ABLE TO PROVIDE OTHER PROBES UPON REQUEST.

## SYSTEM SPECIFICATIONS

Probe S2C for M1-OEM

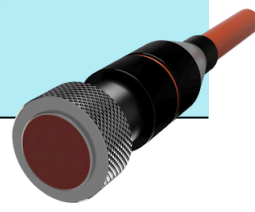
Frequency	2.25 MHz	
Tip Size	13 mm (0.5 in)	
Maximum Depth Rating	300 m (984 ft)	
Range in Steel (Triple - Echo)	3 - 250 mm (0.120 - 10 in)	
Temperature Range	-20°C to +60°C (-4°F to +140°F)	

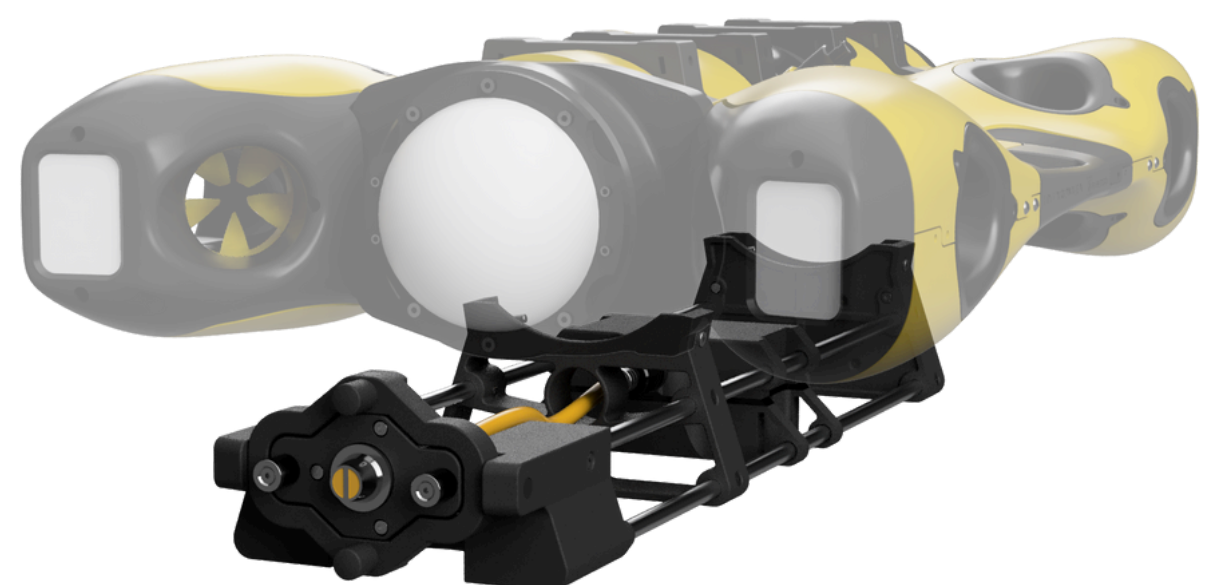
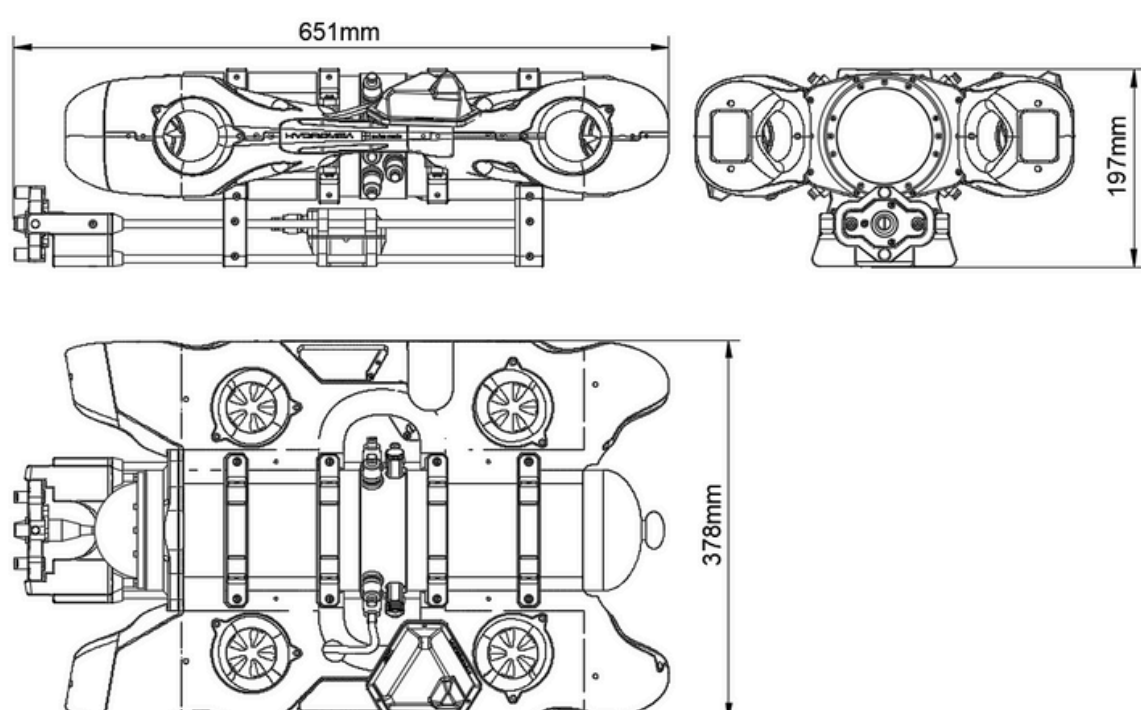

info@hydromea.com  
V1.240926

HYDROMEAA